

# Type 500X

## Electropneumatic Transducer (I/P, E/P)

*Economical and reliable electrical conversion to pressure*

The ControlAir Type 500X converts a current or voltage input signal to a linearly proportional pneumatic output pressure. This versatile instrument is designed for control applications that require a high degree of reliability and repeatability at an economical cost. Optional NEMA 4X (IP65) version allows for splashdown and outdoor installation. Typically, these units are used for applications that require the operation of valve actuators, pneumatic valve positioners, damper and louver actuators, final control elements, relays, air cylinders, web tensioners, clutches, and brakes.

Industries that utilize the Type 500X include Petrochemical, HVAC, Energy Management, Textile, Paper, Paper Converting, Food and Drug



- Low Cost
- Integral Volume Booster
- Compact Size
- Field Reversible
- Low Air Consumption
- Flexible Zero & Span Adjustments
- Standard Process Inputs
- Split Ranging

# Type 500X Low Cost. Compact. Reliable.

The Type 500X is available in two different versions. The lower range model is designed for standard process control applications which typically utilize a 3 to 15 psig output. The extended range unit provides up to 120 psig output for higher pressure industrial pneumatic and process control system requirements.

## Principle of Operation

The Type 500X Transducer is a force balance device in which a coil is suspended in the field of a magnet by a flexure. Current flowing through the coil generates axial movement of the coil and flexure. The flexure moves towards the nozzle and creates back pressure which acts as a pilot pressure to an integral booster relay. Input signal increases (or decreases for reverse acting) cause proportional output pressure increases.

Zero and Span are calibrated by turning adjust screws on the front face of the unit. Adjustment of the zero screw repositions the nozzle relative to the flexure. The span adjustment is a potentiometer that controls the amount of current through the coil.

## NEMA-4X (IP65) Enclosure

Optional Factory Mutual NEMA 4X enclosure rating allows for installation in splashdown or outdoor environments. Unit also meets the requirements of IEC standards IP65.

## Mounting

The Type 500X may be mounted by pipe, panel, or bracket. Field adjustment of the zero may be required if position is changed. High external vibration may cause output fluctuations. Mounting in a vibration-free area is recommended.

## Split Ranging

If split ranging is required the 4-20 mA input, 3-15 psig output version (ControlAir part number 500-AC) can be recalibrated to provide a 3-9 psig or 9-15 psig output.

## Intrinsically Safe

The Type 500X has been tested and approved by Factory Mutual as Intrinsically Safe Class I, II, and III, Division 1, Groups C, D, E, F and G when used with an apparatus meeting the following entity requirements:

**V<sub>max</sub> = 29.9 V C<sub>i</sub> = 0**      **C<sub>i</sub> is capacitance**  
**I<sub>max</sub> = 65 mA L<sub>i</sub> = 35 mH**      **L<sub>i</sub> is inductance**

Installation should be in accordance with ControlAir interconnection drawing no. 431-990-013. This drawing is included in the Type 500X Installation, Operation and Maintenance Instruction. The Intrinsically Safe approval is a standard feature of the Type 500X and applies only to units with a 4-20 mA input signal that are installed with the following barriers:

R.Stahl, Inc. barriers:	MTL, Inc. barriers:
9001/01-280-100-10	728
9002/13-280-110-00	787S+
	4045

The Type 500X is also Factory Mutual Approved as Nonincendive for Class I, Division 2, Groups A, B, C and D, and suitable for Class II and III, Division 2, Group F and G. Barriers are not required for nonincendive rating.

## Field Reversible

In the reverse acting mode the output is the opposite of the direct acting mode (i.e. 4-20 mA input creates a 15-3 psig output). To change from direct acting to reverse acting simply reverse the polarity of the signal leads and recalibrate. Input signal failure causes output pressure to reach maximum value (i.e. 15 psig) when reverse acting.

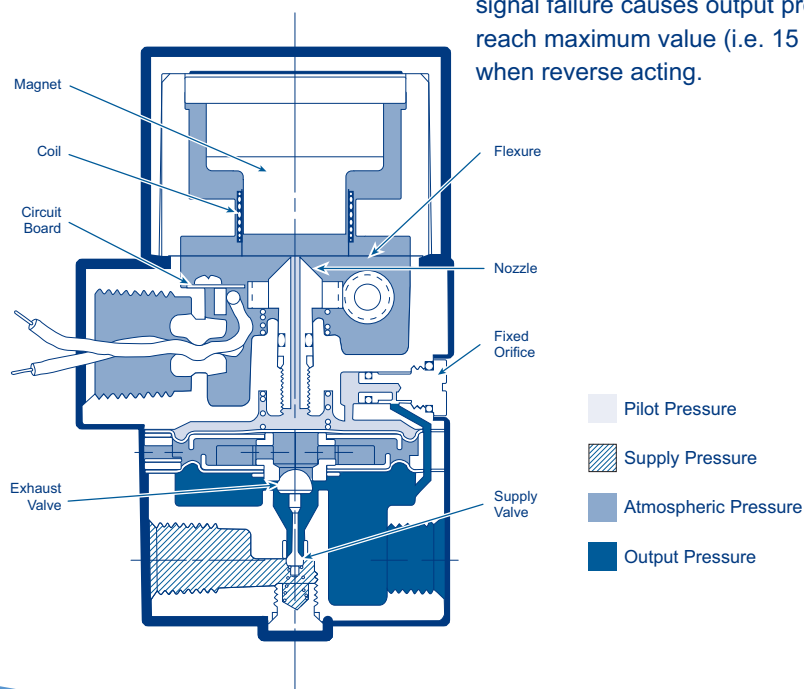



Compact Size

Low Air Consumption

Field Reversible

Standard Process Inputs

Flexible Zero & Span Adjustments

Integral Volume Booster

Split Ranging

## Specifications

	LOW OUTPUT RANGE (UPTO 30 PSIG)	HIGH OUTPUT RANGE (UPTO 120 PSIG)
<b>Min./Max. Supply Pressure</b>	Minimum - 3 psig (21 kPa) Above maximum output Maximum - 100 psig (700 kPa)	Minimum - 5 psig (35 kPa) above maximum output Maximum - 150 psig (1050 kPa)
<b>Supply Pressure Sensitivity</b>	<±0.1% of span per psig (<±0.15% of span per 10 kPa)	<±.04% of span per 1.0 psig (7.0 kPa)
<b>Terminal Based Linearity</b>	<±0.75% of span	<±1.5% of span typical, ±2.0% max.
<b>Repeatability</b>	< 0.5% of span	< 0.5% of span
<b>Hysteresis</b>	< 1.0% of span	< 0.5% of span
<b>Response Time</b>	Dependent on pressure range - typically less than 0.25 sec for 3-15 psig units	
<b>Flow Rate</b>	4.5 scfm (7.6 m3/hr ANR) at 25 psig (175 kPa) supply  12.0 scfm (20.0 m3/hr ANR) at 100 psig (700 kPa) supply	20.0 scfm (34.0 m3/hr) at 150 psig (1050 kPa) supply
<b>Relief Capacity</b>	2 scfm (3.4 m3/hr) at 5 psig (35 kPa) above 20 psig (140 kPa) setpoint	7 scfm (11.9 m3/hr) at 10 psig (69 kPa) above 20 psig (140 kPa) setpoint
<b>Maximum Air Consumption</b>	.05 scfm (.07 m3/hr) midrange typical	.07 scfm (.14 m3/hr) midrange typical
<b>Media</b>	Oil free, clean dry air filtered to 40 micron	
<b>Temp. Range (Operating)</b>	-20°F to +140°F (-30°C to 60°C)	
<b>Port Sizes</b>	1/4 NPT (Pneumatic) 1/2 NPT (Electric)	1/4 NPT (Pneumatic) 1/2 NPT (Electric)
<b>Weight</b>	2.1 lbs. (0.94 kg)	2.1 lbs. (0.94 kg)

## Type 500X Dimensional Drawings

## Type 500X Ordering Information

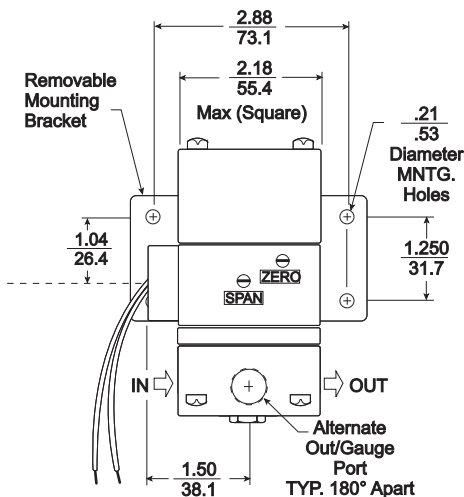
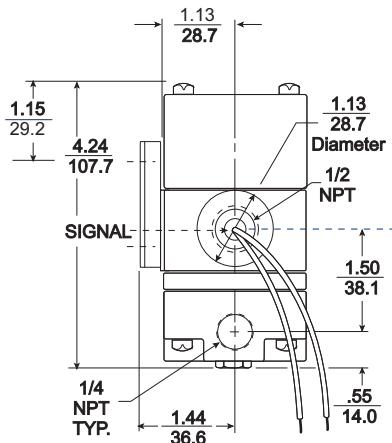
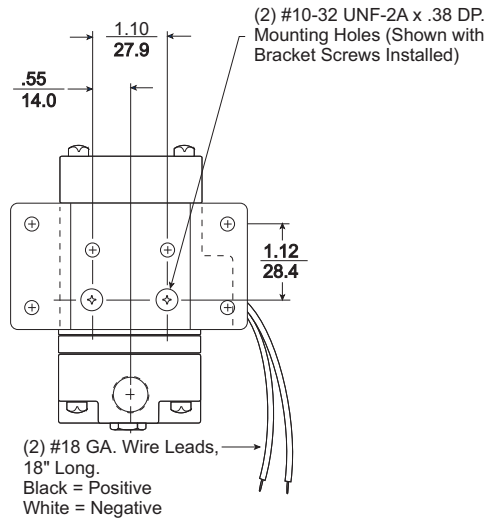

### Type 500X I/P Transducers

Part Number	Input	Output Range		Impedance
		psi	kPa	
500-AA	4-20 mA	3-9	20-60	90 Ohms
500-AB	4-20 mA	9-15	60-100	90 Ohms
500-AC	4-20 mA	3-15	20-100	180 Ohms
500-AD	4-20 mA	3-27	20-185	220 Ohms
500-AE	4-20 mA	6-30	40-200	220 Ohms
500-AF	4-20 mA	1-17	7-117	250 Ohms
500-BC	10-50 mA	3-15	20-100	70 Ohms
500-BD	10-50 mA	3-27	20-185	85 Ohms
500-BE	10-50 mA	6-30	40-200	85 Ohms
500-AG	4-20 mA	2-60*	14-420	225 Ohms
500-AH	4-20 mA	3-120*	20-830	260 Ohms
500-BF	0-60 mA	2-120*	15-830	220 Ohms

### Type 500X E/P Transducers

Part Number	Input	Output Range		Impedance
		psi	kPa	
500-CC	0-5 VDC	3-15	20-100	615 Ohms
500-CD	0-5 VDC	3-27	20-185	530 Ohms
500-CE	0-5 VDC	6-30	40-200	530 Ohms
500-DC	1-9 VDC	3-15	20-100	985 Ohms
500-DD	1-9 VDC	3-27	20-185	840 Ohms
500-DE	1-9 VDC	6-30	40-200	840 Ohms
500-CF	0-5 VDC	2-60*	14-420	500 Ohms
500-EH	0-10 VDC	3-120*	20-830	805 Ohms

\*Output shown is as calibrated at the factory. Large span adjustment capability allows recalibration to achieve output ranges from 3-35 psig (20-240 kPa) with 2-60 psig unit to 3-145 psig (20-1000 kPa) with 2-120 psig unit.



Solução em Instrumentação & Automação

Visite Nosso Site: [www.warme.com.br](http://www.warme.com.br)

Central de Atendimento: (11) 4646-2525

Rua Cana Verde, 110 - Bairro: Jardim Silvestre - Cep: 08584-420  
Itaquaquecetuba - SP

P/N 441-625-005 5/07/02